

NOTE: 18 1/2" DROP

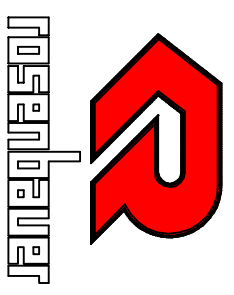
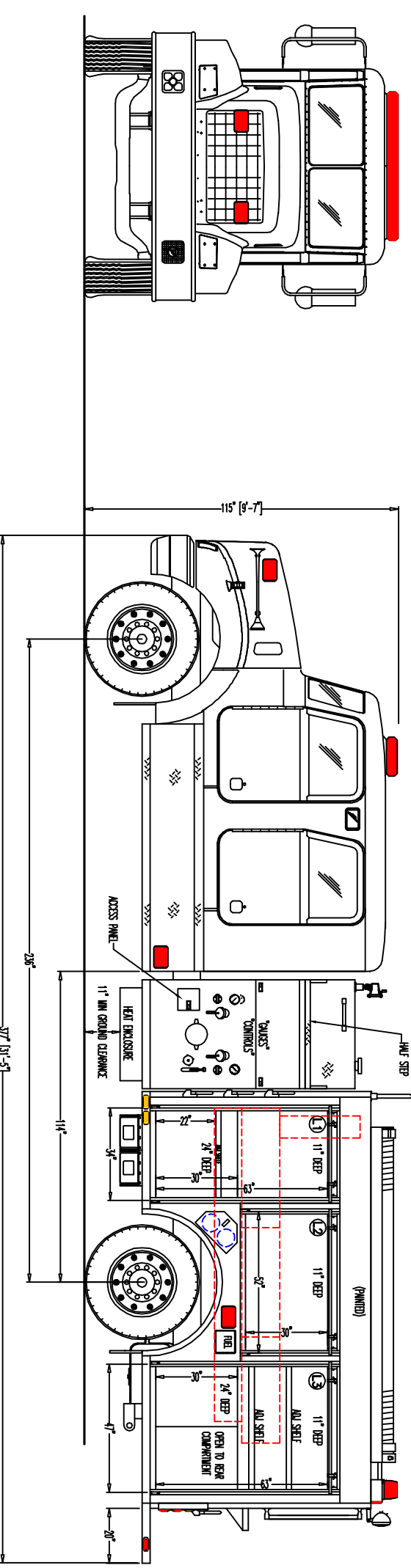

DO NOT SCALE DRAWING.  
 ALL DIMENSIONS ARE APPROXIMATE AND SUBJECT TO ENGINEERING CHANGES DUE TO CHASSIS VARIATIONS. BLUEPRINT DOES NOT NECESSARILY SHOW ALL ITEMS IN THE SPECIFICATIONS.

—PROPOSED—  
 TOLEDO

- NOTES:  
 1. OVERALL HEIGHT IS IN LOADED CONDITION  
 2. 18 1/2" DROP

**GENERAL DIVISION** DWG# P3359-02

REV:	DRWN: 01-18-2008	CHASSIS: PETERBILT 330
	DRWN BY: 1A4	BODY MNT: STAINLESS STEEL
	VEHICLE TYPE: PUMPER	SUBFRAME MNT: STAINLESS STEEL
	FILE # N/A	TANK MNT./MALS: PBY/500/50(FOM)
	SCALE: DNS	WEIGHT FRONT: -
	PUMP: HALF QUIN 1500GPM	WEIGHT REAR: -